



A Touchstone Energy® Cooperative 

NEW CONSTRUCTION HANDBOOK



New Construction Services & Engineering

Montrose Headquarters

11925 6300 Road / P.O. Box 910

Montrose, CO 81401 / 81402

1-877-OUR-DMEA, 1-877-687-3632

24 Hour Emergency Service - 1-877-OUR-DMEA, 1-877-687-3632

www.dmea.com

TABLE OF CONTENTS

General Information	
Application for Service	1
Design and Construction Cost	1
Scheduling and Site Readiness	1
Before New Service Can Be Energized	2
Extra Trip Fee	2
CALL BEFORE YOU DIG - 811	2
Right-of-Way Easements and Access	2
Plant Investment Fee	3
Special Considerations for Motor Loads	3
Electrical Safety Code Clearances	3
Tree Trimming Policy	5
Specifications for Meter Installations	
General	6
Meter Locations	6
Self-Contained Metering Installations	6
Instrument Transformer (CT) Metering Installations	7
Single Member – CT Metering	8
Multiple Members – CT Metering	8
Colorado State Electrical Inspections	9
Working Clearances from Electric Meter	10
Underground Service Installations	
Meter Base on House or Building	11
Meter Pedestal, Permanent and Temporary	12
Trenching Specifications - Primary and Secondary	13
Joint Use Trench	13
Overhead Service Installations	
Overhead Temporary Service	14
Permanent Meter Pole Service	15
Permanent Service - Mast on Building	16
Developer Policy	17
DMEA is “Your Rural Electric CO-OP”	18
NOTES	19

GENERAL INFORMATION

Application for Service

All applications for service from Delta-Montrose Electric Association (DMEA) shall be in accordance with its Extension Policy and Electric Service Regulations. In all circumstances the applicant shall be the fee owner of the property to be serviced by the extension.

By DMEA policy, all electric facilities on the member side of the DMEA meter (Point of Delivery) is constructed by, owned by and the responsibility of the member. Installation of all facilities on the DMEA side of the meter, including the transformer, are designed and installed by DMEA and becomes the property of DMEA unless otherwise noted. It is the responsibility of DMEA to operate and maintain all assets on its side of the meter.

The first step in starting new construction with Delta-Montrose Electric Association (DMEA) is to sign an “Application for New Service” and submit a deposit. This deposit will go towards expenses such as those incurred as part of the design process, and will be applied towards the final cost of the job. The application for new service will place the applicant’s/member’s request for service into the New Construction Schedule and will also be used to establish a billing account for the new service.

Design and Construction Cost

DMEA will handle requests for new construction services in the order the requests are received, but will also consider applicant’s/member’s circumstances and needs when establishing its design and construction schedules. Once the job progresses to the top of the schedule, a System Designer will contact the applicant/member for an onsite appointment. During this appointment the System Designer will go over a check-off list, proposed line routes, equipment locations, permits, right-of-way easements and estimated costs.

Typical DMEA specification drawing details and Colorado State Electrical Inspection information are available on pages 10-16. When complete project information is obtained and required documents are completed, the System Designer will design the job and determine the final cost estimate. All costs shall be determined by DMEA’s current unit construction costs, and will include all costs necessary for the extension of facilities including design expenses, right-of-way investigation, and any necessary licenses and permits. Any changes to the design or additional trips to the site may result in additional expense to the applicant/member.

Once payment is received, the cost of construction will be good for 3 months. Once payment is received, DMEA reserves the right to update the cost of construction if the work has not been completed within 3 months, and/or cancel the job and refund the unused portion.

Scheduling and Site Readiness

Once the job has been designed and paid for, the job will be forwarded to the Line Crew Foreman or Serviceman. At that time the Foreman or Serviceman will be in charge of

scheduling the job. **DMEA assumes no liability for unforeseen factors that delay the project completion date.**

DMEA will own, design, construct, operate, and maintain all facilities, including meters on DMEA's side of the point of attachment for all classes of service.

*Please note that temporary power is allowed for **no more than 12 months** while construction is being completed. DMEA reserves the right to disconnect services that have not transitioned from temporary to permanent after the 12 month period has expired.*

Before New Service Can Be Energized

The **Colorado State Electrical Inspector** must inspect and approve the member's meter base before it can be connected by DMEA (refer to Colorado State Electrical Inspections on page 9):

Montrose County: 1-855-451-9792

W. Montrose County: 1-855-454-0065

Delta County: 1-855-454-0068

www.dora.state.co.us/electrical

The member-furnished trench must be provided in accordance with DMEA's trench specifications (page 13-14). In no circumstance will DMEA be responsible for costs associated trenches including dirt or rock work.

Extra Trip Fee

DMEA reserves the right to assess a flat charge to any member causing a construction delay for DMEA construction crews. A construction delay is any trip to the job site made by a construction crew where the scheduled work could not be completed by the construction crew because conditions at the site were different than what was represented by the member when the appointment was scheduled by the member. **A minimum charge of \$100 per occurrence will be assessed.**

CALL BEFORE YOU DIG - 811

For all underground utility line locates contact the Utility Notification Center of Colorado (UNCC) by dialing **811** at least two business days prior to starting excavation. DMEA or DMEA Sub-contractors will not be responsible for damage to underground facilities that are member owned and have not been accurately located; including, but not limited to septic tank(s), sewer line(s), irrigation pipe(s), sprinkler(s), leach field(s) or any other facilities.

Right-of-Way Easements and Access

If an easement is required for the construction of new power lines, it will need to be obtained prior to installation of the requested service. In the event DMEA has to cross property other than that of the member requesting the service, the requesting member will be asked to obtain all easements needed. A platted and dedicated front lot easement will be provided for utilities in all subdivisions. If the power line is along a county road, DMEA will have an easement of 15 feet. All other easements will be 25 feet (12.5 feet from the center of the installed utility line).

Plant Investment Fee

A Plant Investment Fee of \$1.50 per amp will be added to the cost of any new or upgraded residential or commercial service to fund general improvements to DMEA's electric system.

- Residential facilities requiring a 200 amp service will have a fee of \$300, while a 400 amp service will have a fee of \$600.
- Commercial facilities requiring a 600 amp three-phase service will pay a fee of \$2,700 (((600 amps x 3 phases) = 1,800 amps) x \$1.50 per amp = \$2,700).

Special Considerations for Motor Loads

- Motor loads with variable frequency drives may require: upgrading transformer size (pole class may have to increase), decreasing transformer impedance, increasing service wire size, decreasing service wire length and harmonic filters to reduce Total Harmonic Current Distortion at the member's meter (per IEEE Standards 519). These changes will be at the member's expense.
- DMEA strongly recommends electrical protection on three-phase motors. This protection should include: loss-of-phase, reverse phasing and low-voltage protection (including low-voltage protection for single-phase motors). DMEA will not assume responsibility for damages related to a member's lack of protection.
- Motor loads should be compensated for their reactive power usage by installation of shunt capacitors.
- New installed motors or any other load shall cause less than 3% voltage flicker (per IEEE Standard 141) at the member's meter.

ELECTRICAL SAFETY CODE CLEARANCES

The National Electrical Safety Code is used for the design, construction, maintenance, and operation of DMEA's electric transmission and distribution system. DMEA reserves the right to terminate service without prior notice when a hazardous condition exists. **A specified clearance will be maintained over state highways, all streets, county roads, driveways and residential properties. The National Electric Safety Code, Colorado DOT (Department of Transportation) or the authority having jurisdiction regulates the clearance heights.**

To comply with National Electrical Safety Code requirements, easement and right-of-way finished grades cannot be changed more than six inches by excavation or filling without prior approval of all utility companies involved. Buildings or other structures shall not be constructed within utility easements. **If the member does build within a utility easement, the line will be moved at the member's expense.** Landscaping within an easement is permissible, but shall not violate DMEA's Tree Trimming Policy (see Tree Trimming policy).

Clearances of Secondary Wires, Conductors and Cables

(Refer to the State of Colorado Electrical Inspector or an electrician for more details)

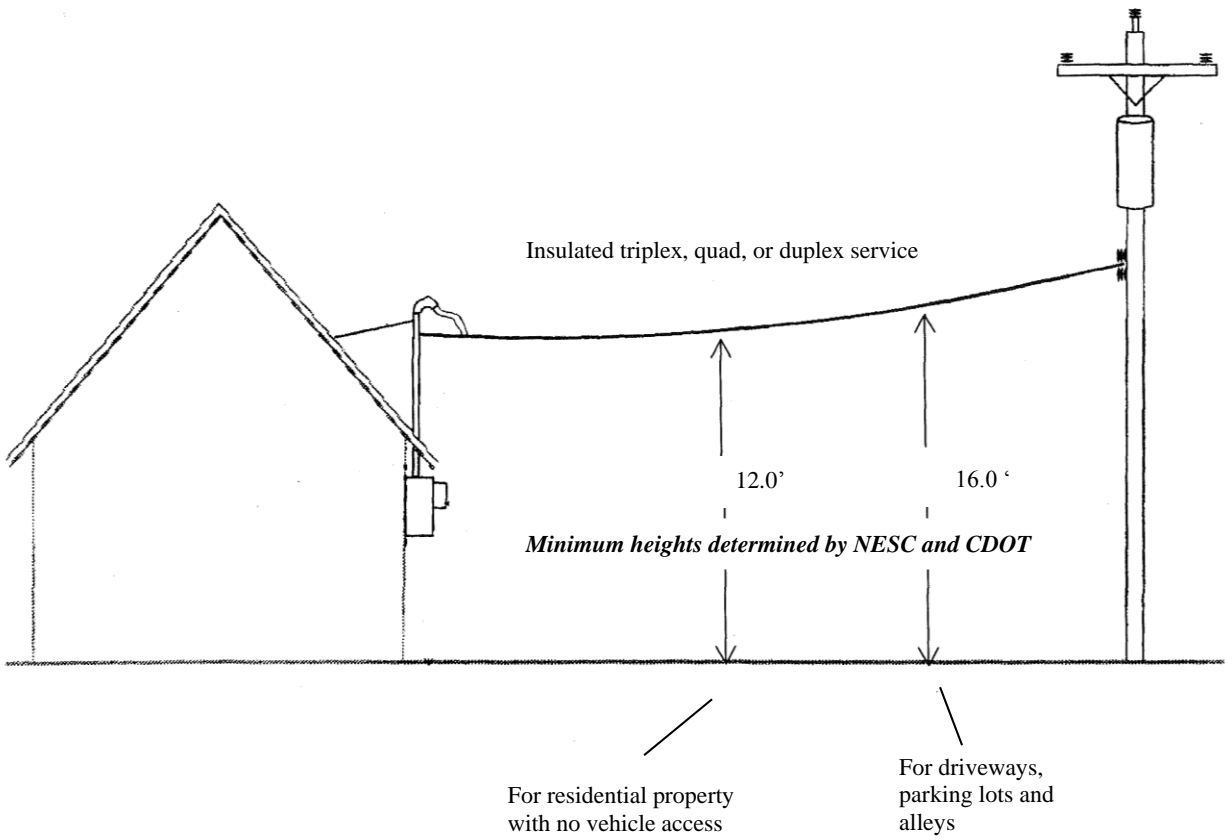

TREE TRIMMING POLICY

The following guidelines shall be used when obtaining right-of-way for the purpose of building and maintaining utility lines.

- Trees, shrubs or bushes shall not be planted directly above underground or below overhead utility lines. Before digging to plant anything, it is the member's responsibility to call 811 to locate the underground utility lines.
- All trees, shrubs or bushes must remain at least five feet on either side of locates and flags designating underground utility lines.
- The member assumes responsibility for all trees, shrubs or bushes that are planted in the utility easements. In the event that DMEA has to excavate any utilities in the easement or maintain any equipment, DMEA will not replace or be responsible for any trees, shrubs or bushes that need to be removed.
- All 120/240/480 volt triplex/quadruplex services must maintain a minimum clearance of a one-foot radius from all trees or branches.
- All open secondary wire will need a minimum clearance radius of 5 feet from all trees or branches.
- All primary wire will require a minimum clearance radius of 10 feet from all trees or branches.
- A DMEA field representative will ensure that all tree trimming is complete prior to constructing a job. No lines will be energized until clearances are met.
- The member always has the option of underground construction (at the member's expense) if the necessary overhead right-of-way clearances cannot be made.
- DMEA is presently utilizing the "Shigo Method" for all tree trimming and maintenance applications. This method is endorsed and promoted by the National Arborist Association.

On all maintenance tree trimming where the member does not allow the Shigo Method, the member has the option to have the tree topped or shaped. If the member elects to have the tree topped or shaped, it will be done at the member's expense. The member will be responsible for all hours spent by the contractor. The member will be required to reimburse DMEA for payment made to the contractor. This will be done every time a tree is trimmed by any option other than the Shigo Method. The ten-foot rule will apply to all primary conductors upon completion of topping or shaping.

Due to insurance and OSHA regulations, only tree trimming contractors hired by DMEA are allowed to work within ten feet of primary conductors.

With these guidelines in place, and by utilizing the Shigo Method for tree trimming, DMEA will rotate on a three-year cycle for tree trimming and tree removal. This cycle will save DMEA and the member money.

SPECIFICATIONS FOR METER INSTALLATIONS

General

DMEA will make permanent connections between the member's electric service wiring and DMEA's system. Unauthorized connections are not permitted. DMEA will furnish, maintain and retain ownership of all meters and instrument transformers. Terminations will only be allowed on the exterior of the facility being metered. No DMEA termination will be inside or enter the member's facility.

Removal, relocation or performing of any work on an electric meter without DMEA's permission is prohibited. Tampering with DMEA's metering equipment, making an unmetered connection, or making an unauthorized reconnection to DMEA's system is prohibited and the member will be subject to disconnection and/or fines.

DMEA is not responsible for member owned facilities, such as, but not limited to meter bases/loops.

Meter Locations

- **Meters will be located: 1) at the lot-line, 2) on the front of the house, 3) within the front third of the front corner of the house, or 4) the street side and Always Accessible and Safe.**
- **If a member-owned meter base/loop (contingent upon DMEA approval) is located on a DMEA secondary pole, it will be at the member's expense to relocate their facilities in the event the pole is damaged or needs to be replaced.**
- **Meters will not be located in any area considered hazardous, flammable or where reading, testing or servicing of the meter may become impractical, (i.e. behind fences, enclosures, or shrubs, under decks, around dangerous animals, or inside structures). If meters are not accessible, they will be moved by DMEA at the member's expense.**
- Meters will be located no less than 3'6" and no more than 5'6" above final grade.
- No steps or stairways will be permitted as access to meters.
- **Meters will be located at least 4' away from gas meters.**
- Meters are owned, installed and maintained by DMEA.
- Multiple meter sockets must each be clearly marked with **permanent metal scribed tags** (at the member's expense) to identify correct addresses. Correct meter labels and appropriate addresses shall be verified by member's electrician before permanent meters will be installed.
- DMEA will not attach its supply wires to more than one meter on a single structure, unless the meters are grouped together in such a manner that all are energized through the same transformer (Electric Service Regulations III.O).

Self-Contained Metering Installations

For single-phase self-contained metering installations, the member provides and maintains the meter socket, and DMEA provides (at the member's expense) and maintains the meter.

For single-phase services requiring power at 120/240 having a service rating of 200 amps or less, a properly sized self-contained UL approved 4 jaw meter socket will be installed. A 240/480 volt single-phase service requires a 400 amp disconnect with **manual lever bypass switch** and accessible main disconnect. A 120/208 single phase self-contained network meter must be provided with a 5 terminal socket with the 5th terminal in the 6 o'clock position.

The member provides and maintains all 3-phase self-contained meter sockets including multiple meter stacks. Three-phase self-contained meter sockets with a **manual lever bypass switch** will be UL-Listed (Landis + Gyr or Square D). All other sockets must receive prior approval before the metering equipment is ordered. A sample of the meter socket will be sent, including job name and number, to DMEA, attention: Equipment Tech Foreman.

Any **commercial** account that requires a self-contained meter, including network meters, must have a **manual lever bypass switch**. Self-contained meter sockets with a manual lever bypass switch will be UL-Listed (preferred Landis + Gyr or Square D). All other sockets must receive prior approval before the metering equipment is ordered. A sample of the meter socket will be sent, including job name and number, to DMEA, attention: Equipment Tech Foreman.

For single-phase services with a capacity greater than 200 amps and including, but not exceeding 400 amps, a 400 amp (320 amp continuous rating) meter socket will be installed with a minimum service wire size of 350 MCM, a **manual lever bypass switch**, locking jaws and a disconnect or disconnects that will de-energize the entire panel. *Disconnects must be accessible to DMEA personnel.* The continuous load for these services shall not exceed 320 amps. Meter bases with a continuous rating of 400 amps or sockets for bolt-in meters are not acceptable.

In the event of a failure, the member or a licensed electrician will replace the meter socket and wire within the service mast. Inspection will be required by the State Electrical Inspector if wire within service mast has to be replaced. DMEA will not be responsible for any code violations found outside the scope of DMEA work.

Instrument Transformer (CT) Metering Installations

- DMEA provides and maintains (at the member's expense,) all single-phase and three-phase CT-metered meters and meter sockets except for multiple meter stacks.
- CT's will be located in a CT cabinet furnished by the member, unless otherwise approved by the DMEA Engineering Department. For CT cabinets 800 amps or less, the customer will provide a UL-Listed bar-mounted CT cabinet. For CT cabinets more than 800 amps (which require a switchgear cabinet) the CT cabinet specification will be approved by the DMEA Engineering Department.
- The point of demarcation will be the member furnished bar-mounted CT cabinet or weatherhead. The cabinet must meet minimum NEC size requirements.
- For terminations in the bar-mounted CT cabinet, the member will provide the approved connectors and terminate all wires within the box.
- DMEA will provide conduit and wire and will pull wire to the CT cabinet.
- Members will not have access to DMEA's transformer, only DMEA will have this access. DMEA will make all connections in the transformer.

- CT's will only be located within the transformer if there are no other services attached to the transformer. Therefore, the transformer must be dedicated to only one meter or service.
- Meters may be attached directly to the transformer and can be preinstalled by DMEA's meter personnel.
- Terminations will only be allowed on the exterior of the facility being metered. No DMEA termination will enter the member's facility.
- CT meter sockets will not be mounted on switchgear doors or cabinets.

Single Member – CT Metering

Where a single member is or will be served from a single or three phase transformer, CT's will be installed in the transformer or in a CT cabinet mounted on the member's facility and furnished by the member. The minimum size CT cabinet will be 32" by 36" by 10". No CT's will be mounted on poles or external to cabinets or transformers. The meter can be attached directly to the transformer or mounted next to the CT cabinet at member's facility. If CT's are installed inside the transformer, the point of demarcation will be at the location where the wires enter the member's furnished CT cabinet or what the State Electrical Inspector refers to as the "splice box". DMEA will supply and install (at the member's expense) all wire and conduit to the CT cabinet or splice box. DMEA's System Designer will determine the number and size of wire and conduit to be installed. The service entrance knockouts in the CT cabinet or splice box are the responsibility of the member and location of the knockouts will be specified by DMEA. The member will provide all connectors and terminate all wires inside the CT cabinet or splice box.

Multiple Members – CT Metering

Where more than one member is or will be served from a single or three phase transformer, the CT's must be installed in a CT cabinet mounted on the member's facility and furnished by the member. For CT cabinets 800 amps or less, the member will provide a UL Listed bar-mounted CT cabinet with the bars included. For CT cabinets more than 800 amps, the CT cabinet specification will be approved by the DMEA Engineering Department. The meter will be mounted next to the CT cabinet at the member's facility. The point of demarcation will be the member furnished bar-mounted CT cabinet or weatherhead. DMEA will supply and install all wire and conduit (at the member's expense) to the member furnished connectors in the CT cabinet. DMEA's System Designer will determine the number and size of wire and conduit to be installed. The service entrance knockouts in the CT cabinet or splice box are the responsibility of the member and location of the knockouts will be specified by DMEA. The member will provide all connectors and terminate all wires inside the CT cabinet.

A DMEA Operations or Engineering Manager/Supervisor must approve any exceptions to the above in writing.

COLORADO STATE ELECTRICAL INSPECTIONS

A service entrance (meter socket on building, meter pedestal, or meter on pole) is required to be inspected by the **State of Colorado Electrical Inspector** before final connection can be made. State law (Title 12 Article 23-116 C.R.S. 1973) states that no utility shall provide service to any person required to have electrical inspection without proof of final approval. State Inspections are required only on the member side of the meter.

The member or member's Electrical Contractor must obtain an electrical permit from the State of Colorado prior to starting work. It is the responsibility of the member to contact the inspector when the work is ready for inspection.

The phone numbers for the **State Electrical Inspector** are:

Montrose County: 1-855-451-9792

W. Montrose County: 1-855-454-0065

Delta County: 1-855-454-0068

www.dora.state.co.us/electrical

When the work is approved, the inspector will tag the meter base with a green or yellow-lettered sticker. If the work is not satisfactory, a red sticker will be placed on the meter panel and must remain there until the work is done correctly and re-inspected. When the State Electrical Inspector has approved the electrical work, it is the member's responsibility to contact the DMEA System Design Customer Service Representative to schedule the service to be connected and a meter installed at:

1-970-240-1256, 1-877-OUR DMEA extension #256 or 1-877-687-3632 extension #256.

Electricians needing Short Circuit Currents for Commercial Installations (per NEC 110-24) to pass State Electric Inspections, should plan on at least three business days to obtain this information from a System Designer at DMEA.

Inactive Service Inspection: After 6 months of a service being disconnected or de-energized, the property owner must obtain an electrical inspection by the Colorado State Electrical Inspector to verify a safe system still exists. Upon DMEA-approved evidence of inspection, DMEA will connect and energize the system.

WORKING CLEARANCES FROM ELECTRIC METER

(Refer to the State of Colorado Electrical Inspector or an electrician for more details)

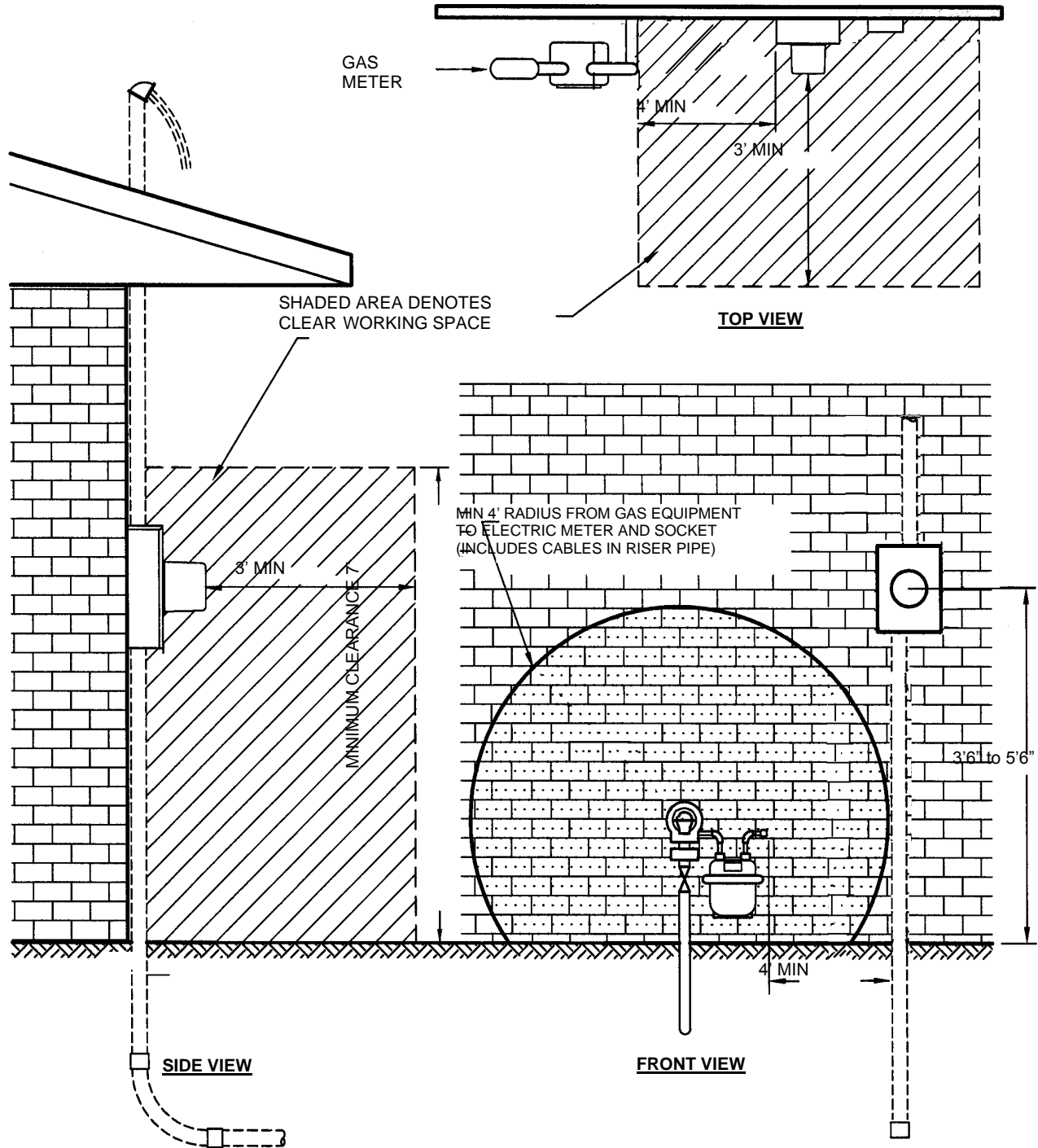

UNDERGROUND SERVICE INSTALLATIONS

(Refer to the State of Colorado Electrical Inspector or an electrician for more details)

METER BASE ON HOUSE OR BUILDING

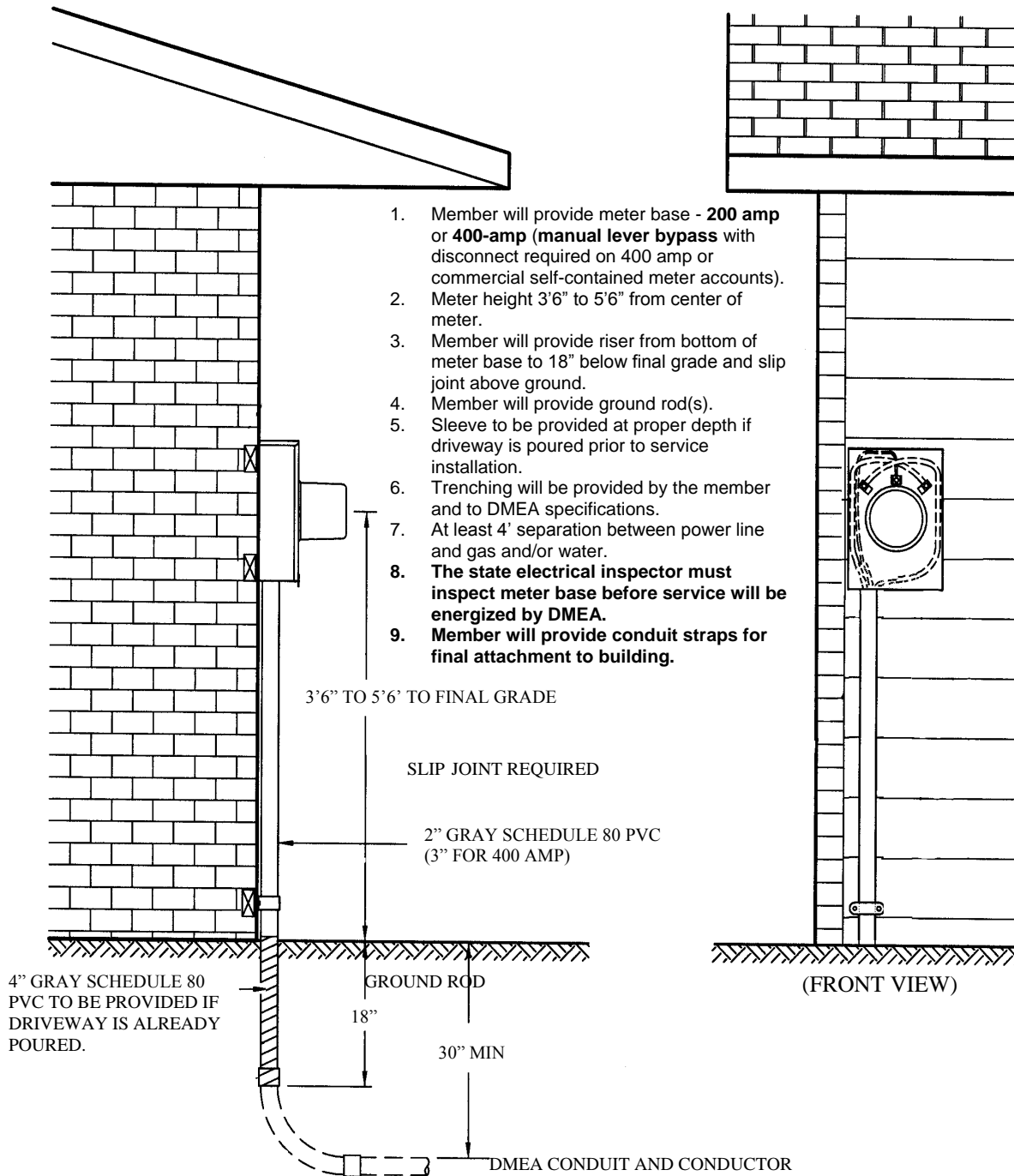

UNDERGROUND SERVICE INSTALLATIONS

(Refer to the State of Colorado Electrical Inspector or an electrician for more details)

PERMANENT METER PEDESTAL

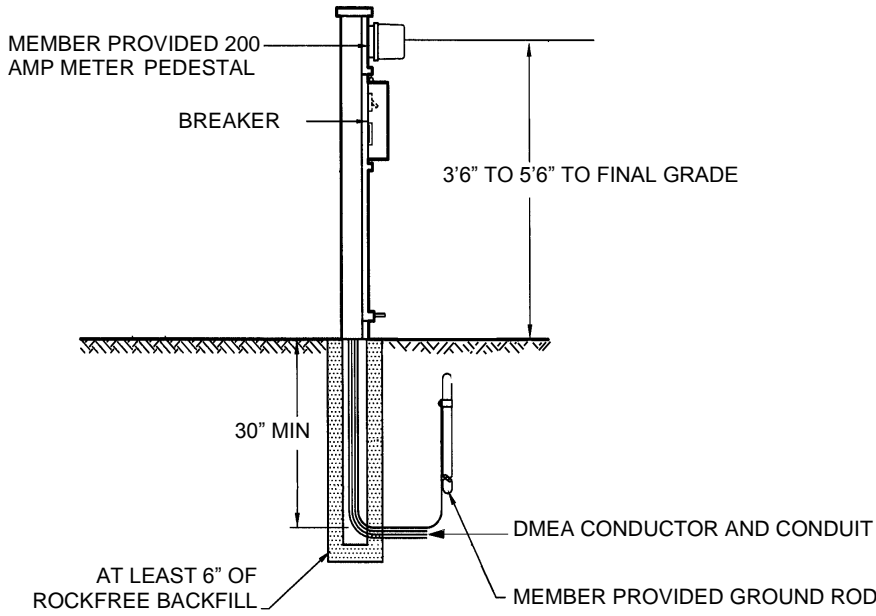

NOTES:

1. Member will provide meter base/pedestal. **200 amp (400-amp breaker) is required at meter pedestal on all installations. Manual lever bypass** with disconnect is required on 400 amp or commercial self-contained meter accounts.
2. Meter height 3'6" to 5'6" from center of meter.
3. Member will provide riser from bottom of meter Base to 18" below final grade and slip joint above ground.
4. Member will provide ground rod(s).
5. Sleeve to be provided at proper depth if driveway is poured prior to service installation.
6. Trenching will be provided by the member and to DMEA specifications.
7. At least 4' separation between power line and gas and/or water.
8. **The state electrical inspector must inspect meter base before service will be energized by DMEA.**

TEMPORARY METER PEDESTAL

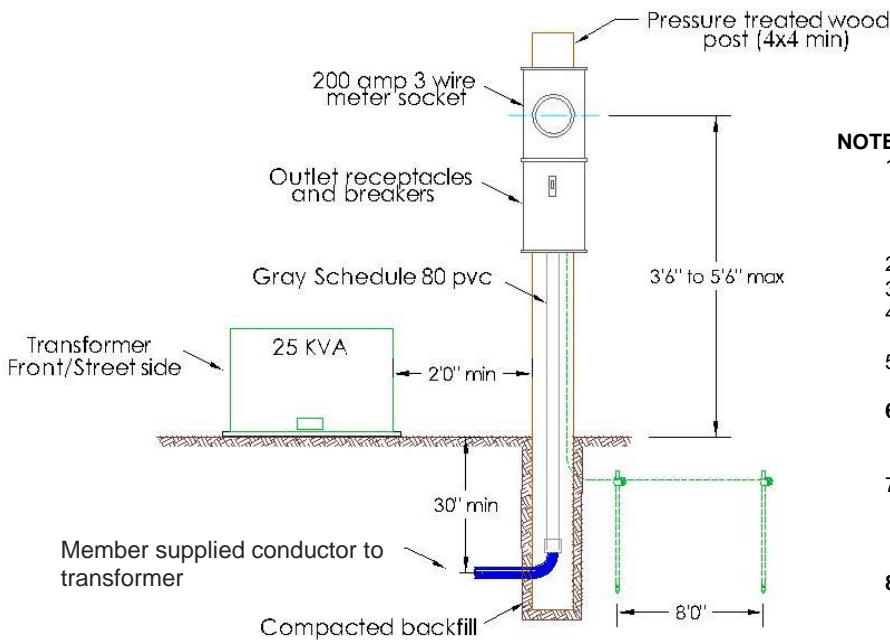

NOTES:

1. Member will provide the whole temporary meter pedestal (post, meter socket, breakers, conduit, outlets, and enough wire to reach from temporary to the inside of the transformer).
2. Meter height 3'6" to 5'6" from center of meter.
3. Member will provide ground rod(s).
4. Trenching will be provided by the member and to DMEA specifications.
5. At least 4' separation between power line and gas and/or water.
6. **The state electrical inspector must inspect temporary meter pedestal before service will be energized by DMEA.**
7. Temporary meter pedestal will be set no less than 2' from transformer and no more than 10' unless pre-approved by a DMEA System Designer, Line Crew Foreman, or Serviceman.
8. **200 Amp (or 400 amp) breaker is required at meter pedestal on all installations.**

UNDERGROUND SERVICE INSTALLATIONS

Trenching Specifications (Primary and Secondary)

- Conduit or secondary underground service conductor will not be installed to member's facility until an inspected meter base is in place. All conduit and conductor will be installed by DMEA.
- Member will provide a clean, rock-free trench with a 6" bedding of rock-free dirt or sand above and below the conductor and conduit.
- Primary trenches will be 48" deep with a 6" bedding of rock-free dirt or sand. The conductor will be 42" below final grade.
- Secondary trenches will be 36" deep with a 6" bedding of rock-free dirt or sand. The conductor will be 30" below final grade.
- Depths specified are to finished grade.
- It is the responsibility of the member to make sure the trenches are in the allotted easements on their property.
- DMEA employees will not enter trenches that do not meet OSHA's excavation standards, 29 CFR 1926.651. (Spoils must be a minimum of 2 feet back from the trench).
- Gas, sewer and water lines will not be included in an electrical trench. There shall be at least four feet of horizontal separation from DMEA conductor where other trenches are in the same proximity.
- When gas or water lines cross in the trench with electric lines, there must be at least one foot of vertical separation.
- Conductor will not be energized until backfill is properly completed.
- DMEA will supply marking tape to be placed 12" above conductor.

Conductor

Primary Trench

Secondary Trench

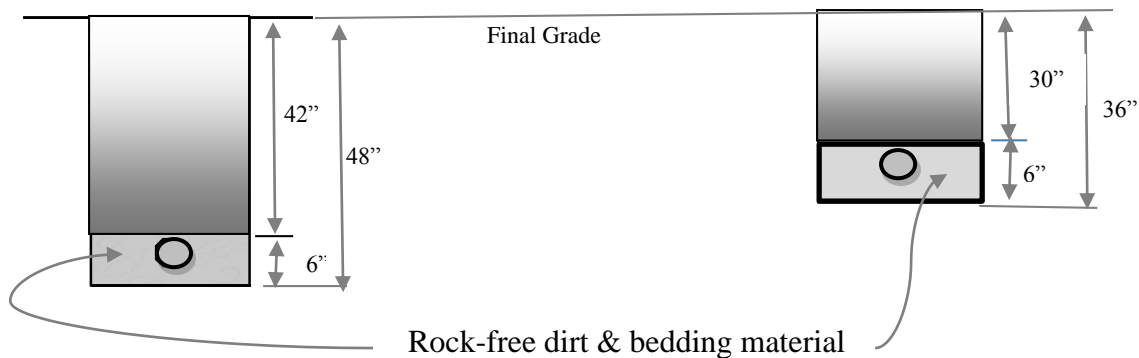

Joint Use Trench

Members and developers requiring a joint use trench where telephone and television cable are within the electric trench are solely responsible for all coordination between the included utilities. All utilities requesting joint-use trenches must be designed and ready to be installed at the time the DMEA facilities are scheduled for construction. A minimum 1-foot separation is required between electrical and all other services that share the trench.

Although utilities such as phone and television cables are allowed in DMEA trenches, for the safety of personnel, DMEA does not allow customer-owned installations such as control cables, wiring or 120/240 V secondary service wires. Any customer whose trench does not meet the above specifications and causes the Line Crew or Serviceman an extra trip will be subject to an additional fee.

OVERHEAD SERVICE INSTALLATIONS

(Refer to the State of Colorado Electrical Inspector or an electrician for more details)

OVERHEAD TEMPORARY SERVICE

NOTES:

1. Member will provide the whole temporary meter pedestal (post, meter socket, breakers, GRC conduit, outlets, and enough wire to reach from temporary to the inside of the transformer)
2. Meter height 3'6" to 5'6" from center of meter.
3. Member will provide ground rod(s).
4. At least 4' separation between power line and gas and/or water.
5. **The state electrical inspector must inspect temporary meter pedestal before service will be energized by DMEA.**
6. Post will be set a minimum of 10' and a maximum of 15' from transformer pole unless otherwise approved by a DMEA System Designer, Line Crew Foreman, or Serviceman.

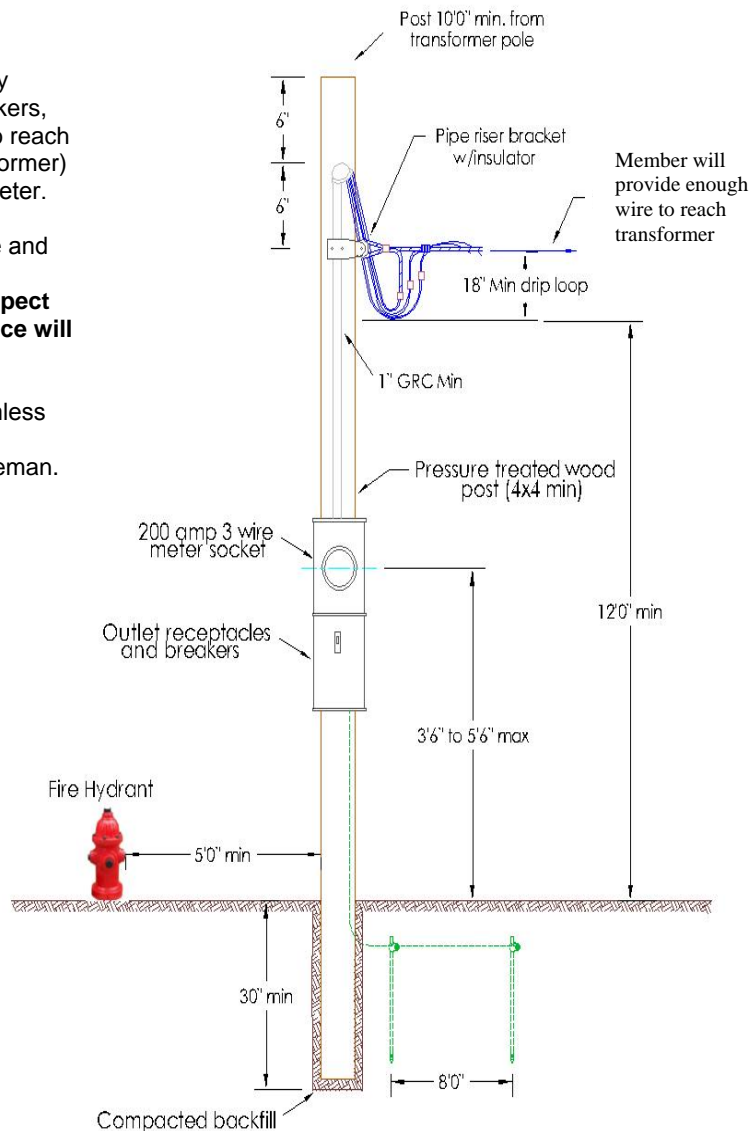

PERMANENT METER POLE
SERVICE: SALVAGE ONLY-

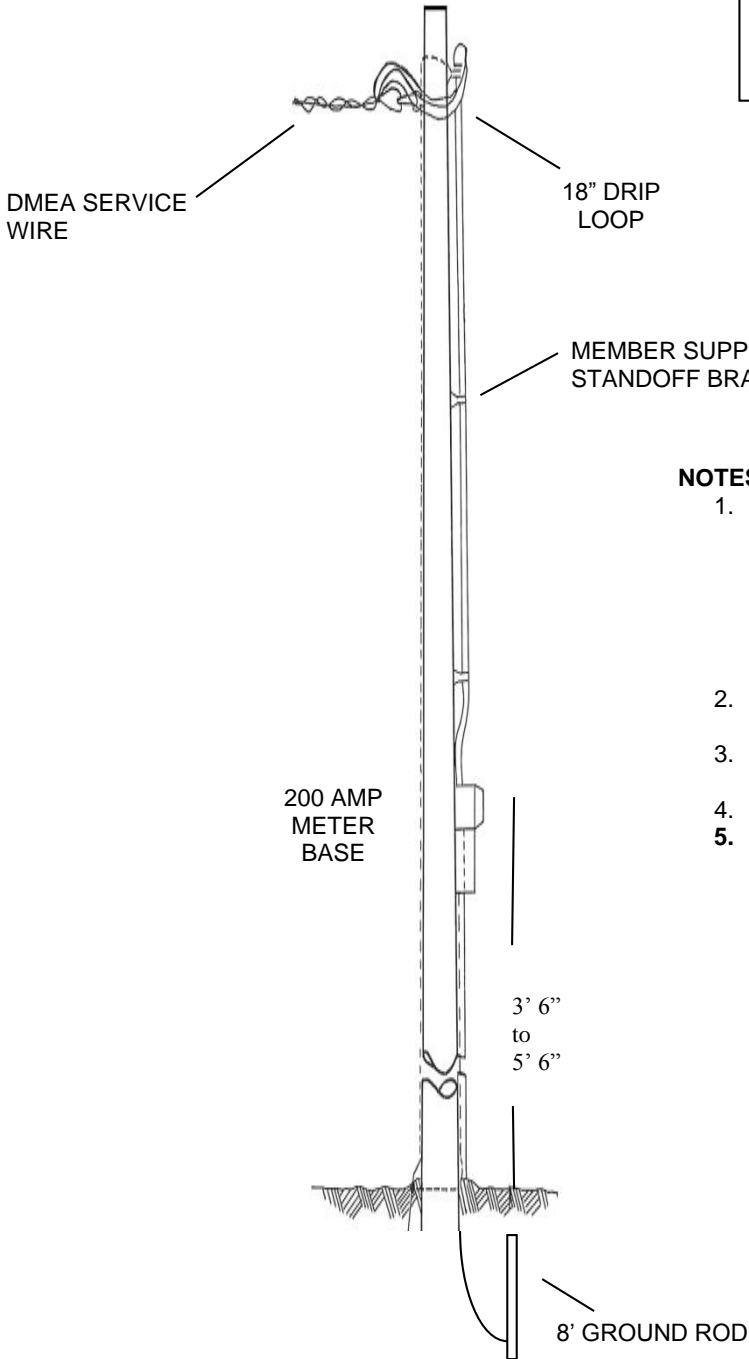

Point of Attachment shall be at least 6" below the weatherhead, but no more than 12" maximum.

NOTES:

1. Member will provide meter base - **200 amp** or **400-amp (manual lever bypass)** with disconnect required on 400 amp or commercial self-contained meter accounts), GRC conduit up the pole, and at least an 18" tale of wire outside of the weatherhead.
2. Meter height 3'6" min to 5'6" from center of meter.
3. At least 4' separation between power line and gas and/or water.
4. Member will provide ground rod(s).
5. **The state electrical inspector must inspect meter base before service will be energized by DMEA.**

OVERHEAD SERVICE INSTALLATIONS

(Refer to the State of Colorado Electrical Inspector or an electrician for more details)

PERMANENT SERVICE - MAST ON BUILDING

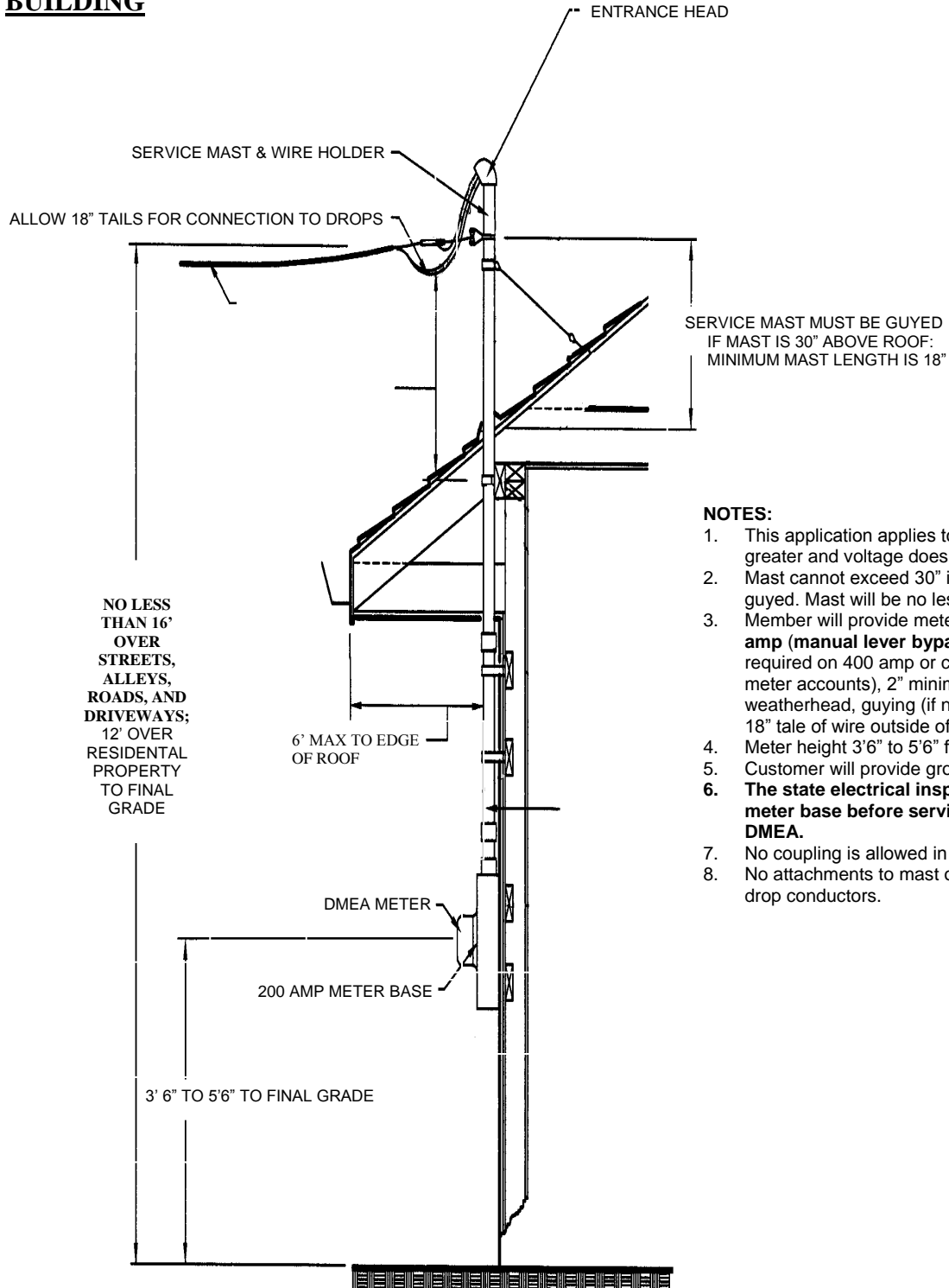

NOTES:

1. This application applies to a slope of 4" in 12" or greater and voltage does not exceed 300 volts.
2. Mast cannot exceed 30" in height without being guyed. Mast will be no less than 18".
3. Member will provide meter base - **200 amp** or **400-amp (manual lever bypass)** with disconnect required on 400 amp or commercial self-contained meter accounts), 2" minimum GRC conduit, mast, weatherhead, guying (if needed) and at least an 18" tale of wire outside of the weatherhead.
4. Meter height 3'6" to 5'6" from center of meter.
5. Customer will provide ground rod(s).
6. **The state electrical inspector must inspect meter base before service will be energized by DMEA.**
7. No coupling is allowed in the top 10' of the mast.
8. No attachments to mast other than power service drop conductors.

DEVELOPER POLICY

Definition of a Developer

A person or an entity who develops a piece of property into more than two lots, duly approved by the governing body of the city, county, or state; with the intent being the sale of said lots for profit.

Responsibilities of the Developer

The developer shall, in advance, provide to DMEA an accurate plat of the subdivision tract duly approved by and filed with the county, city or any other entity having jurisdiction, showing the location of lots, streets, alleys, existing buildings, existing utilities, and any other underground installations or obstructions. The Developer will provide and identify permanent right-of-way easements that are compatible with DMEA's policies for design, installation, operation, and maintenance of the system including the necessary access to and from the development. **DMEA requires front lot line easements for underground electric facilities.** The Developer will provide DMEA with all pertinent load data to be used in design. **It is also the responsibility of the developer to make sure the trenches for the primary wire are in the easements. The Developer will provide permanent final grade and property corner pins prior to the installation of underground facilities.**

Process for submitting electronic plats for developments and subdivisions

The DMEA System Design Department and Geographic Information Systems require all developers to submit to DMEA the latest and most updated (preliminary) electronic version of their development **before a DMEA System Designer can meet with persons involved in planning the backbone for that development.** This information will be used to post the development to DMEA's mapping system and for use in laying out the electric backbone for that development.

There are several ways a developer can get the requested electronic plat to DMEA. All versions of the plat should be in an AutoCAD (.dwg) format. The document can be burned to a compact disc and submitted to DMEA at the time the developer signs up for service. The developer can also upload the document on a USB memory stick (jump or thumb drive) and bring it to DMEA to download the information. Or, the developer can post the plat to DMEA's file transfer protocol site. The address for this site is:

ftp://ftp.dmea.com
User ID: dmeaftp
Password: i12ftp2dmea

Once at the site, open the "Electronic Plats" folder and upload the plat. E-mail or call the GIS Department (gis@dmea.com or 970-240-1259) to let DMEA know that your information is posted.

Please inform DMEA in the manner listed above if anything in the development changes.

DMEA is “Your Rural Electric CO-OP”

Board of Directors

DMEA is a private, non-profit rural electric cooperative owned and controlled by the members it serves. Individuals become members when they apply for and receive electric service. Cooperative members have an ownership interest in the cooperative through their dollar investment. At present there are seven districts and two at-large regions identified within DMEA’s service territory, each with a board member representative. *These nine directors set the policies and direction for DMEA.* For more information about the Board of Directors, contact DMEA at 1-877-OUR-DMEA, (1-877-687-3632) or visit www.dmea.com.

[Intentionally Left Blank]

